

INSTALLATION INSTRUCTIONS

HILLSVIEW 1

30
LIT5212WH/BK-40-WE
50



INSTRUCTIONS PERTAINING TO RISK OF FIRE OR INJURY TO PERSONS
READ ALL INSTRUCTIONS

IMPORTANT SAFETY INSTRUCTIONS

SAVE THESE INSTRUCTIONS

TOOLS AND MATERIALS REQUIRED:

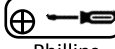

Phillips Screwdriver

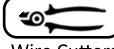

Wire Cutters



Pliers



Wrench

Wiring supplies as required by the Canadian Electrical Code and/or the Quebec Electrical code

SAFETY PRECAUTIONS:

1. TURN OFF ELECTRICAL POWER BEFORE STARTING INSTALLATION OF LIGHT FIXTURE.
2. THIS PRODUCT MUST BE INSTALLED IN ACCORDANCE WITH THE APPLICABLE INSTALLATION CODE BY A PERSONE FAMILIAR WITH THE CONSTRUCTION AND OPERATION OF THE PRODUCT AND THE HAZARDS INVOLVED.
3. CAUTION RISK OF FIRE. CONSULT A QUALIFIELD ELECTRICIAN TO ENSURE CORRECT BRANCH CIRCUIT CONDUCTOR.
4. FOR EXTREMAL USE ONLY, RECOMMEND APPLYING WATERPROOF SILICONE TO SEAL AROUND TRIM AND CEILING.

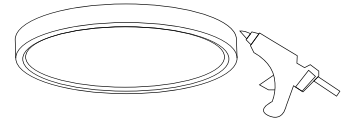

PACKAGE CONTENTS

PART	DESCRIPTION	QTY	NOTE
A	LED Low Profile Flushmount	1	
B	Mounting screws	2	
C	Wire nut	3	
D	Mounting bracket	1	

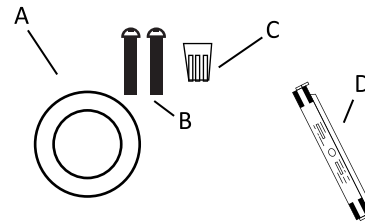

FLUSH MOUNT

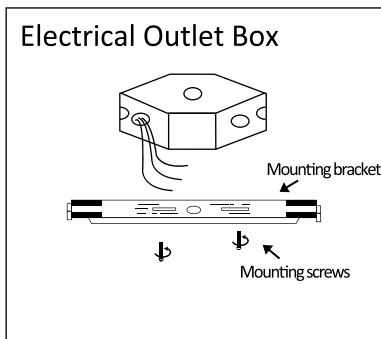

1. Prior to installation, install mounting bracket into the electrical outlet box with mounting screws. Drive screws completely to the end of the junction box.

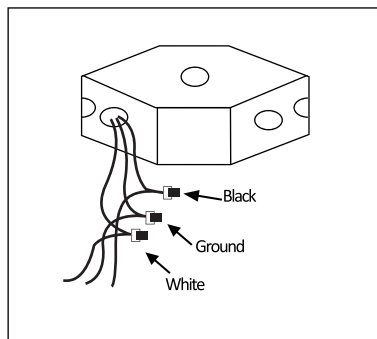

2. Connect supply wires to wires on fixture with wire nuts or push wires into Quick Connector. Connect white to white, black to black, and copper wire to copper wire as grounding connection.

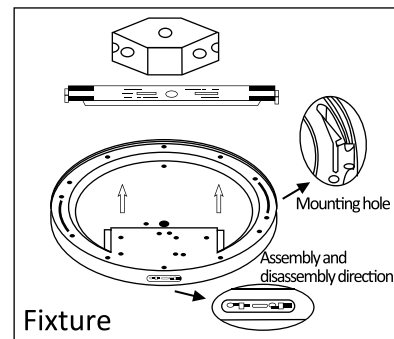

3. Attach the fixture to the mounting bracket: Screw the fixture to the mounting bracket in the direction of assembly and disassembly shown on the fixture

RECOMMENDED DIMMERS LUTORN #CTCL -13P, PVCL-153P