

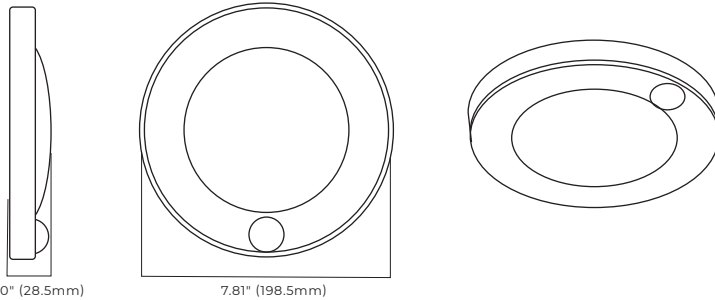

4"/6" LED Closet Light with Monitor Sensor

LED Disc Closet provides surface mount for new construction applications. Unit fits most 4" junction boxes Fire rated boxes. It's suitable for wet location.



Technical Specifications
 Voltage: 120v, 60Hz ac operation.
 Diffuser: Translucent White PC Opal Diffuser.
 Hardware: All mounting screws and wire connectors.
 Too Use: Phillips Screw Driver and Glue gun.
 Warranty: Five year, limited warranty.

WARNING: For your safety read and understand instructions completely before starting installation. Before writing to power supply, turn off electricity at the fuse or circuit breaker box.

SURFACE MOUNT INSTALLATION

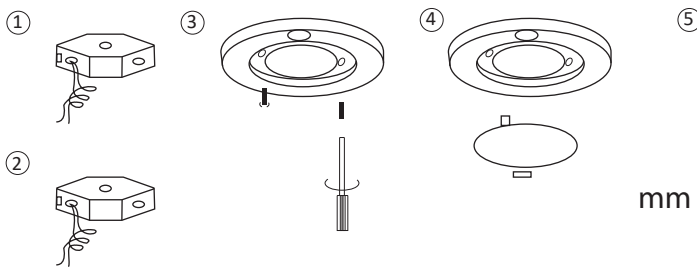

- Step 1) Prior to installation. Please install two screws (furnished) into the junction box. Do not drive screws completely to the end of the junction box.
- Step 2) Connect supply wires to wires in fixture wiring box with proper size wire nuts or push wires into "push-in" connector. Connect white to white, black to black, and green or bare copper wire to bare copper wire.
- Step 3) With a Phillips screwdriver, attach the disk light tightly to the j-box.
- Step 4) Complete the installation by twisting the diffuser on the disk light aluminium enclosure and lock the diffuser in place.
- Step 5) The edge of the fixture and the ceiling use water-proof silicone to seal.

WARNING:

- Risk of Fire**
Supply conductors (power wires) connecting the fixture must be rated minimum 90°C if uncertain, consult an electrician
- Risk of Electric Shock**
Disconnect power at fuse or circuit breaker before installing or servicing.
- Risk of Fire/of Electric Shock**
If not qualified, consult an electrician

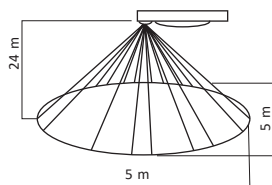

Ceiling Mount sensor Detection Range

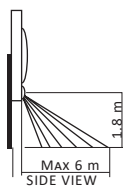

Wall Mount sensor Detection Range

When motions is detected, it automatically turning lights ON and turns the light after 30 vseconds when the room isvacared